

E4-WM5-Y764A00

MOUNTING INSTRUCTION



IMPORTANT! READ THIS FIRST!

Installation of shock absorbers requires special tools and expert knowledge. Accordingly, installation of all BILSTEIN products must be performed by a professional automotive suspension technician.

When replacing other brands, BILSTEIN shock absorbers should always be installed as a set. All BILSTEIN products must only be used for the specific, intended application as indicated in the application guide. **Any use of any BILSTEIN product other than for its intended use may result in serious bodily injury or death.**

Always use a chassis hoist for the installation of BILSTEIN products and make certain that the raised vehicle is securely attached to the hoist and/or supported to prevent the vehicle from slipping, falling, or moving during the installation process.

If you install any BILSTEIN product without the necessary special tools, expertise, and chassis hoist, you may subject yourself to the risk of serious bodily injury or death.

BILSTEIN shock absorbers are gas-filled and are highly pressurized.

- Never place any BILSTEIN product in a vise or use a clamp on any BILSTEIN product.
- Never apply heat near any BILSTEIN product.
- Never attempt to open or repair any BILSTEIN product, in order to prevent **serious bodily injury or death.**

Any attempt to misuse, misapply, modify, or tamper with any BILSTEIN suspension product voids any warranty and **may result in serious bodily injury or death.**

While installing any BILSTEIN product:

- Do not use impact tools for loosening or tightening fasteners, because this may destroy the screw threads.
- Self-locking fasteners must only be used **once!**
- Reuse original equipment components only if they are in good condition, otherwise replace them with new components.
- Never remove the slight film of oil on the piston rod and seal.
- All mounting fasteners for shocks and struts must be securely tightened before tension is placed on the suspension system, unless otherwise specified in the manufacturer's service manual or in this instruction.

After installing any BILSTEIN product:

- The suspension caster and camber must be checked and/or adjusted to comply with the vehicle manufacturer's specifications.
- The (load dependent) brake compensator and the anti-lock brake system must be checked and/or reset to comply with the vehicle manufacturer's specifications.
- The headlight aim must be checked and adjusted.

E4-WM5-Y764A00 MOUNTING INSTRUCTION

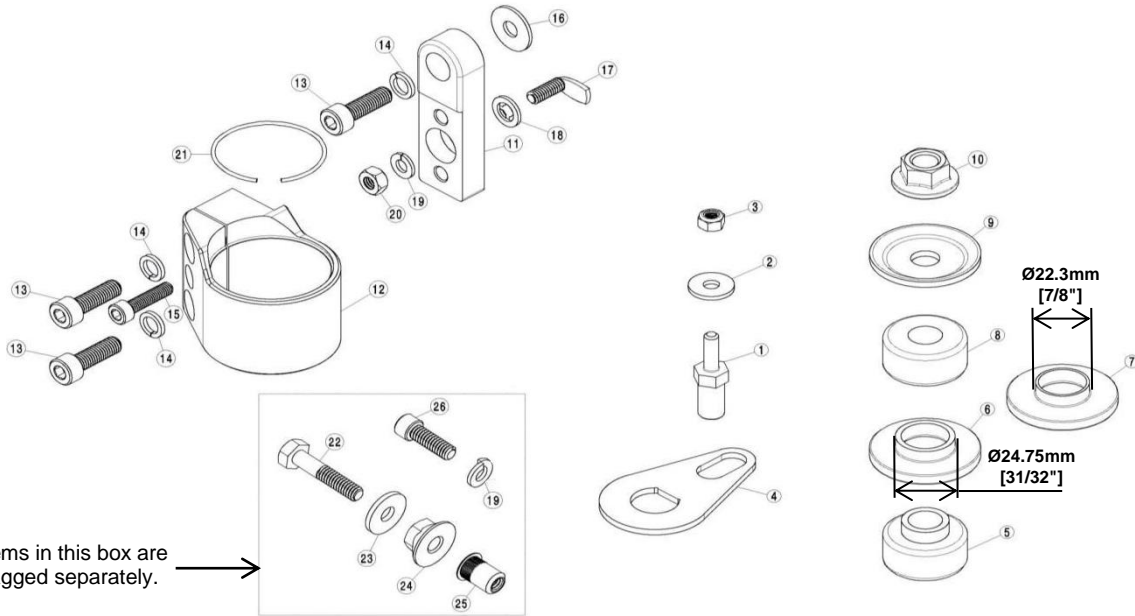

Items in this box are bagged separately.

Bill of Materials		
Item #	Description	Qty
1	Anti Rotation Pin	1
2	Washer; 1/4" ID x 3/4" OD	1
3	Nylock; M6x1	1
4	Anti Rotation Plate	1
5	Bushing; Lower	1
6	Alignment Washer; '10-	1
7	Alignment Washer; '03-'09	1
8	Bushing; Upper	1
9	Concave Washer	1
10	Flange Locknut; M12X1.25	1
11	Reservoir Bracket Adapter	1
12	Reservoir Bracket	1
13	M8x1.25 x 25mm SHCS	3
14	Split Lock Washer (for M8x1.25 x 25 SHCS)	3
15	M6x1 x 25mm SHCS	1
16	Nylon, 8mm, Washer	1
17	Stud, Right-Angle	1
18	Nylon Retaining Washer	1
19	Split Washer; 1/4"	2
20	Hex nut, 1/4"-20	1
21	Snapping	1
22	Hex Head Cap Screw, 1/4"-20, L=1.25"	1
23	Washer	1
24	Serrated Flange Nut	1
25	Threaded Insert	1
26	SHCS 1/4"-20, L=3/4"	1



B8 5160 reservoir shock installation procedure:

B8 5160 reservoir shocks are corner specific. The step by step procedure is shown with pictures below. See pages 14 and 15 for the end result.

- A. Remove the existing shock from the vehicle following all procedures in the vehicle manufacturer's service manual. Inspect the OE lower shock bolt/washer for any damage or excessive wear. If these components are in good condition, save them for reuse later. If damage or excessive wear is present on any of these components, purchase the required replacement OE components.
- B. Find the Reservoir Bracket and appropriate hardware shown in Figure 1 below.
 - o **Note:** The Reservoir Bracket orientation is different for the Left (Driver) and Right (Passenger) side. Refer to Figure 1 below.

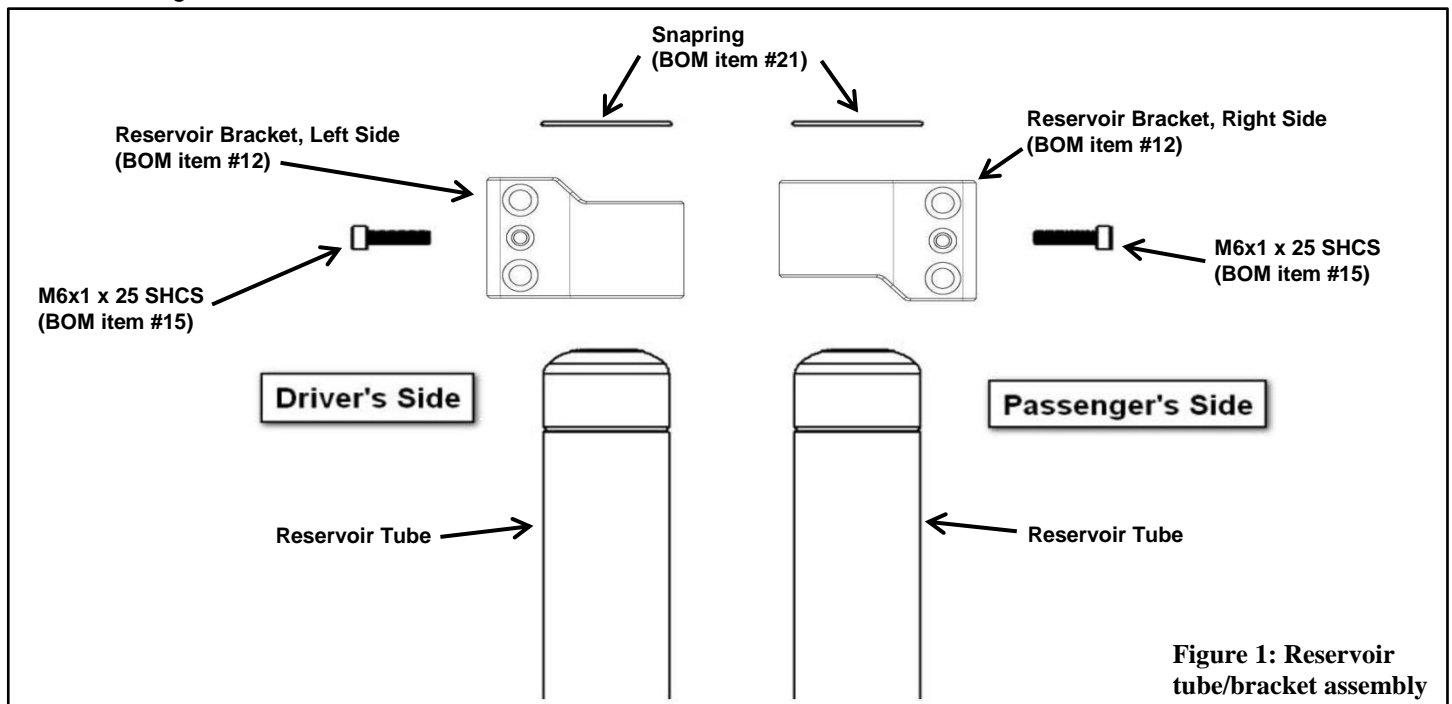

Figure 1: Reservoir tube/bracket assembly

- C. Slide Reservoir Bracket (BOM item #12) down over the Reservoir Tube and install the Snapping (BOM item #21) into the groove as shown in Figure 2.

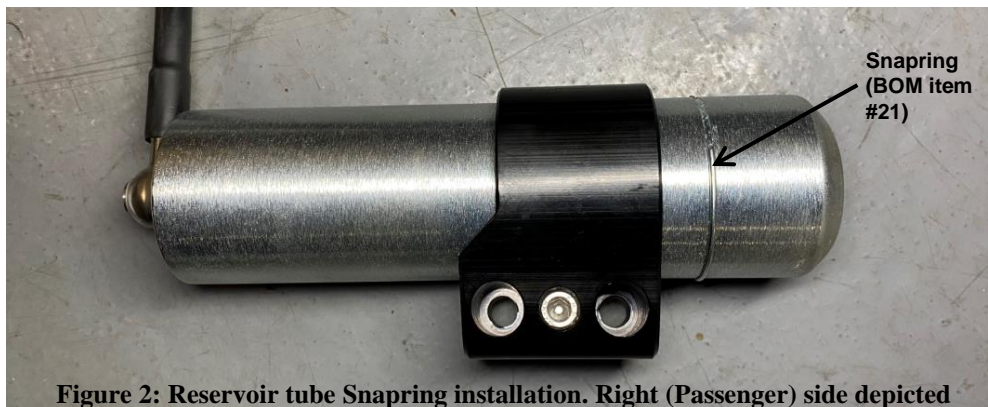
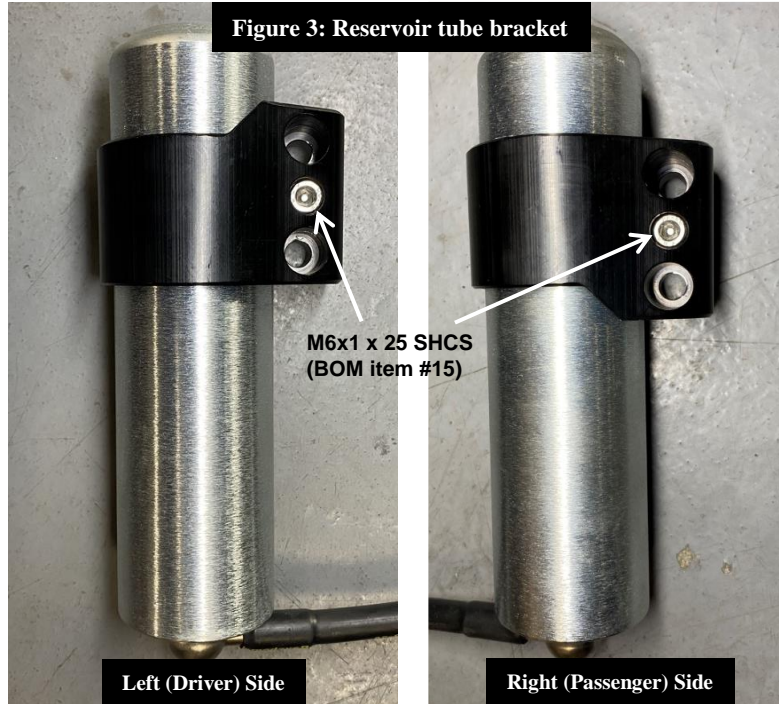

Figure 2: Reservoir tube Snapping installation. Right (Passenger) side depicted

E4-WM5-Y764A00 MOUNTING INSTRUCTION



- D. Slide the Reservoir Bracket up over the Snapping until it bottoms out. Verify the Reservoir Brackets are oriented on each side as shown below in Figure 3.



- E. Apply non-permanent thread locker to the M6x1 x 25 SHCS (BOM item #15).
- F. Screw in the M6x1 SHCS using a 5mm hex driver.
- **Torque: 5 ft-lb (7 Nm)**
- G. Figure 4 shows the vehicle frame rail on the driver side toward the front of the wheel well. There are two existing holes in the frame rail that will be used to secure the reservoir bracket. The upper hole has a M8x1.25 thread, the lower hole is oval and has no threads. For vehicles not equipped with the M8x1.25 thread in the upper mounting hole, refer to steps H through N below. If the M8x1.25 threaded hole is present, skip to step O and BOM items in the dotted box on page 2 can be discarded (BOM items #19 and #22 through #26).

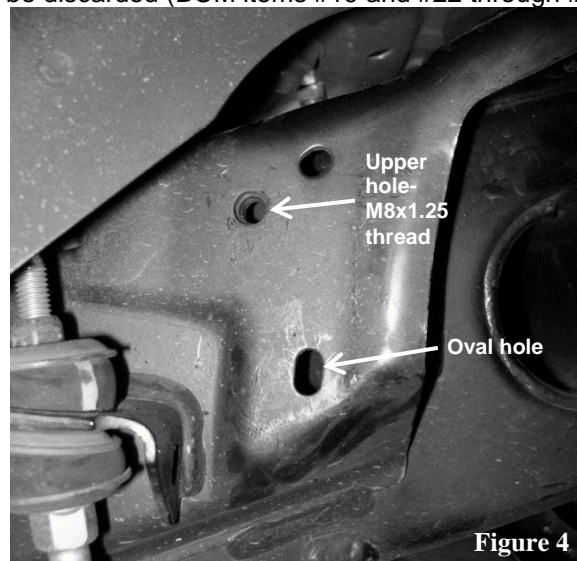

E4-WM5-Y764A00 MOUNTING INSTRUCTION



Process for installing Threaded Inserts into frame

- H. Discard quantity 1 of the M8 hardware shown here in Figure 5:



- I. Use the following hardware in exchange for the discarded M8 hardware shown above in step H. See Figure 6.

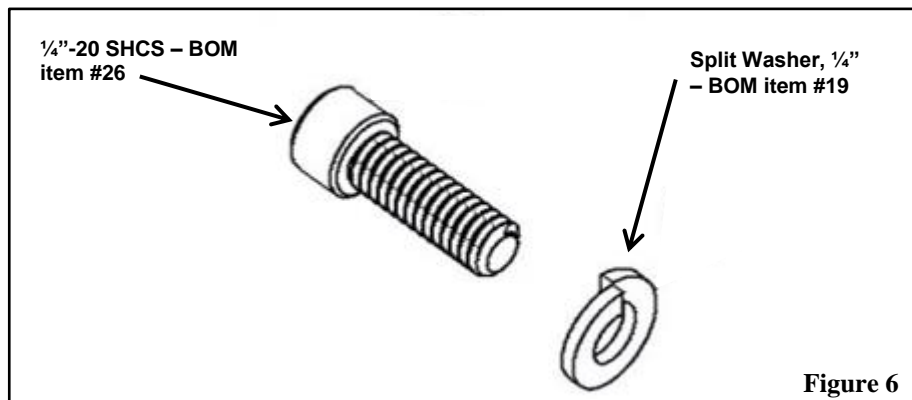

- J. The upper hole on the frame is 0.35" in diameter. It must be drilled out to 0.39" using a 25/64" drill bit (not provided).
- K. If you have access to a threaded Insert gun or pliers, that may be preferable to set the provided threaded inserts. Otherwise, using the BOM items shown below and a 1/2" box end wrench, arrange them as shown and turn the 1/4"-20 hex head cap screw by hand until it is snug. Refer to Figure 7 and Figure 8.

Note that the screw will pass through the serrated flange nut without engaging the threads. The threads will instead engage the threaded insert. The serrations on the flange nut prevent the threaded insert from rotating while setting it.

E4-WM5-Y764A00 MOUNTING INSTRUCTION

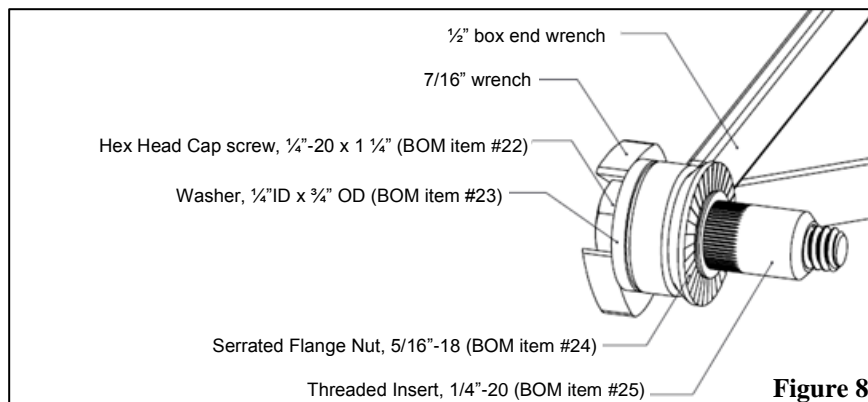
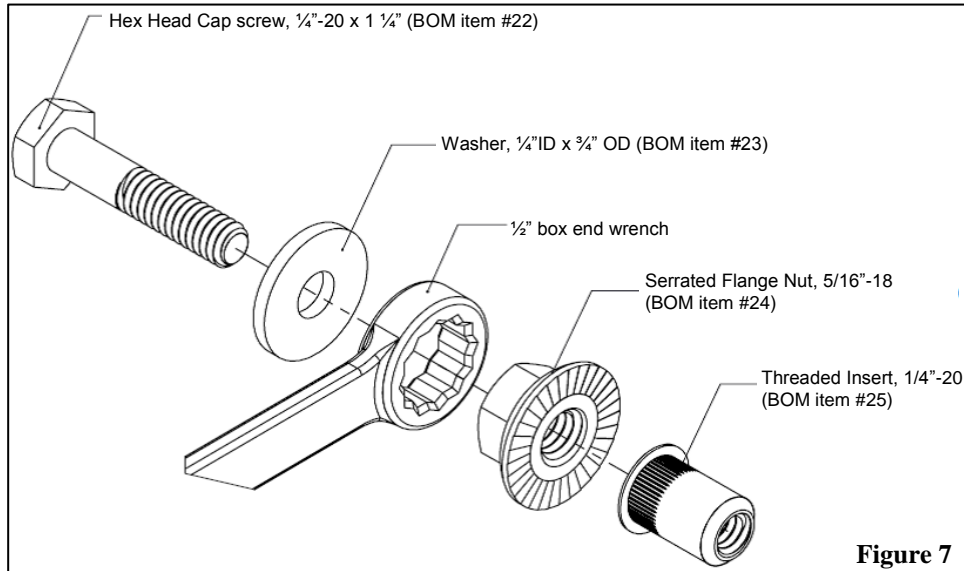

L. Insert the threaded insert into the drilled out hole.



M. While keeping the threaded insert flange firm and parallel against the frame rail, tighten the screw using a 7/16" box end wrench or socket. Turn it 2.5 rotations to set the threaded insert. Tightening in 1/4 turn increments tends to work well.

E4-WM5-Y764A00 MOUNTING INSTRUCTION



Figure 10

- N. Remove the screw, washer, and flange nut. The threaded insert should now be rigidly fixed in the hole as shown below.

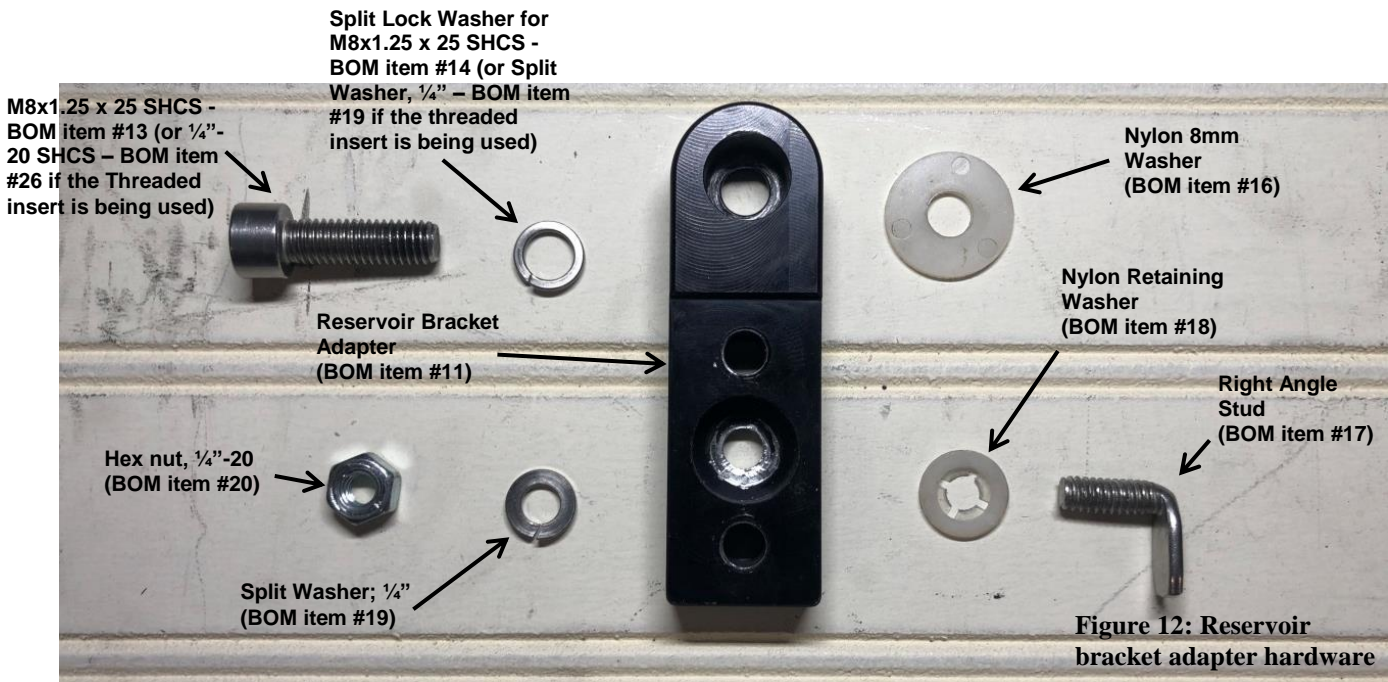

Figure 11

E4-WM5-Y764A00 MOUNTING INSTRUCTION



- O. Find the Reservoir Bracket Adapter and appropriate hardware for each side. Refer to Figure 12:



- P. Slide the Nylon Retaining Washer over the Right Angle Stud, and then insert the threaded end of the stud into the back of the Reservoir Bracket Adapter as shown in Figure 13.
- Q. From the other side, slide the Split Washer over the Right Angle Stud threads, and then thread on the Hex nut, 1/4"-20 by hand until snug. Refer to Figure 13.

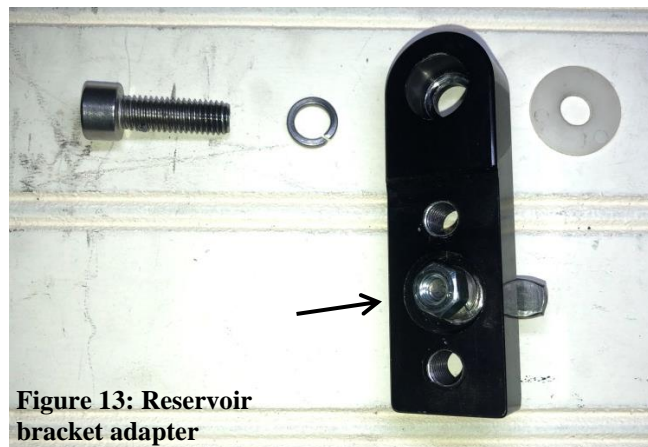

- R. Insert the Right Angle Stud into the hole as shown in Figure 14. With the Reservoir Bracket Adapter hanging upside down, slide the M8x1.25 SHCS through a Split Lock Washer (for M8x1.25 SHCS), and then into the remaining counter bored hole. Then slide the Nylon Washer over the exposed threads of the M8. Refer to Figure 14. If the threaded inserts were installed, discard the M8x1.25 SHCS (BOM item #13), Split Lock Washer (BOM item #14), and Nylon 8mm washer (BOM item #16). Instead use the SHCS 1/4"-20, L=3/4" (BOM item #26) and 1/4" Split Washer (BOM item #19), refer to steps H and I.

E4-WM5-Y764A00 MOUNTING INSTRUCTION



- S. Apply non-permanent thread locker to the remaining exposed M8 or 1/4-20 threads.
- T. Swing the Reservoir Bracket Adapter right side up and screw the M8x1.25 (or 1/4"-20) SHCS into the threaded hole in the chassis. Use a 6mm hex driver (or 3/16 hex driver if using the 1/4"-20 SHCS). Using a 7/16" socket, tighten the Hex nut, 1/4"-20. Refer to Figure 15.

Note: The tab on the stud will catch on an interior feature of the frame which will prevent it from rotating and allow the nut to be tightened. (In the event that the bracket ever needs to be removed from the vehicle, the nylon retaining washer will prevent the stud from falling into the frame when the nut is removed).

- Torque for M8x1.25 SHCS or SHCS 1/4"-20, L=3/4": 10 ft-lb (13.6 Nm)
- Torque for Hex nut, 1/4"-20: 8 ft-lb (10.9 Nm)

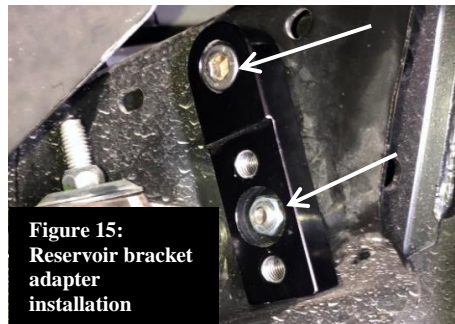

- U. Place the Anti-Rotation Pin (BOM item #1) into the frame hole circled in white below. This hole is towards the front of the shock mount hole. Refer to Figure 16.

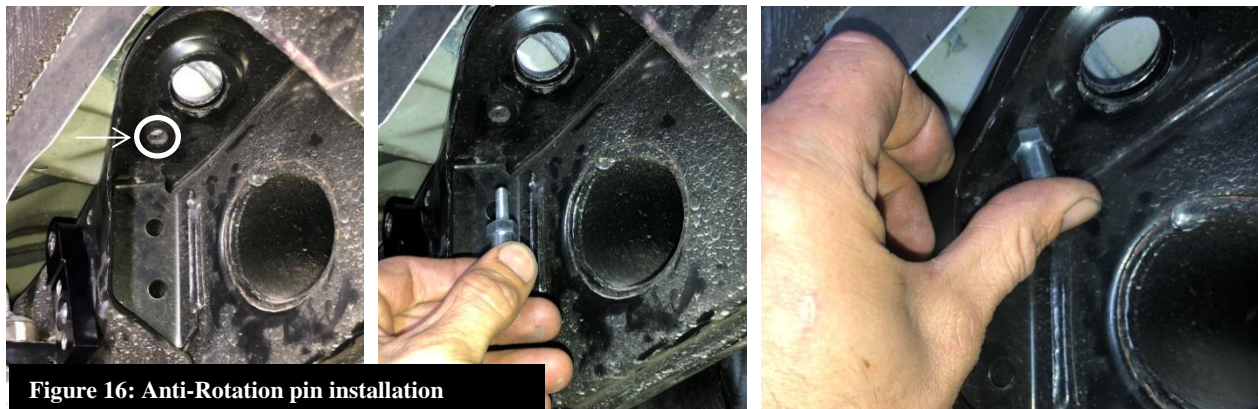

Left (driver) side depicted. Right (passenger) side is a mirror image.

E4-WM5-Y764A00 MOUNTING INSTRUCTION



- V. Hold the Anti Rotation Pin with a ½" or 13mm deep socket. Place the Washer (BOM item #2) over the threaded stem from the top side of the frame. Thread the Nylock; M6x1 (BOM item #3) onto the stem. Then, hold the Anti Rotation Pin assembly towards the rear of the vehicle and tighten the Nylock with a 10mm ratcheting wrench. Refer to Figure 17.
- **Torque the Nylock; M6x1 to 7 ft-lb (10 Nm).**



Left (Driver) side

Right (Passenger) side

- W. Slide the Anti Rotation Plate (BOM item #4) over the threaded pin and onto the shock body as shown in Figure 18. Verify the D-ring hole in the plate seats over the D-ring boss at the base of the pin. Failure to lock this D-ring into place as shown below may cause your shock to rotate which could create interference issues.

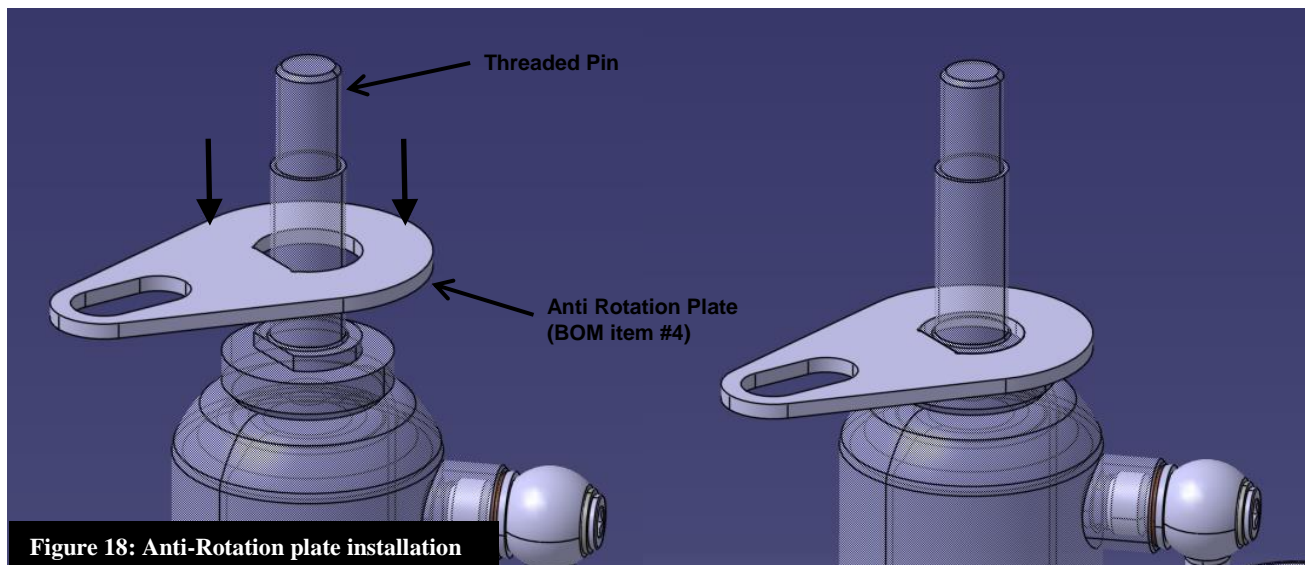

E4-WM5-Y764A00 MOUNTING INSTRUCTION



- X. Slide the Lower Bushing (BOM item #5) and the appropriate Alignment Washer for your vehicle (BOM item #6 or #7 depending on year; see BOM on page 2) over the threaded pin on the shock body as shown in Figure 19.

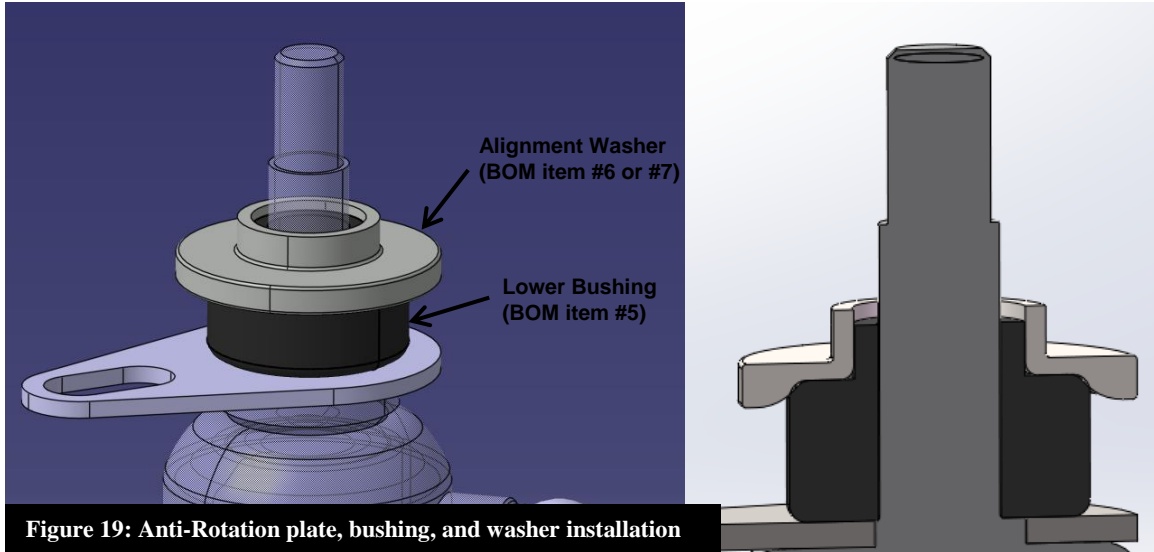

- Y. Place the threaded pin on the shock body through the chassis mount. Guide the Anti Rotation Plate (BOM item #4) so it captures the Anti Rotation Pin (BOM item #1) and carefully center the Alignment Washer (BOM item #6 or #7) in the chassis mount hole. Refer to Figure 20.



Left side depicted. Right side is a mirror image.

- Z. Slide the Upper Bushing (BOM item #8) over the threaded pin, followed by the Concave Washer (BOM item #9). **Verify the Concave Washer is installed concave side up as shown in Figure 21 and Figure 22.** Then thread the Flange Locknut (BOM item #10) onto the threaded pin on the shock body. Tighten the Flange Locknut using an 18mm ratcheting wrench.
- **Torque the Flange Locknut to 20 ft-lb (27 Nm).**

E4-WM5-Y764A00 MOUNTING INSTRUCTION



You should now have the following, refer to Figure 21 and Figure 22:



Figure 21: Top mount/stem parts installation complete

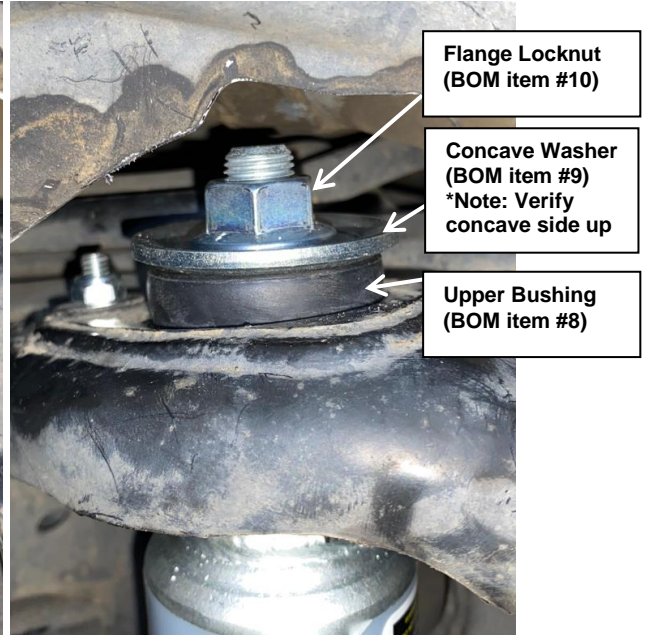

Flange Locknut
(BOM item #10)

Concave Washer
(BOM item #9)
*Note: Verify
concave side up

Upper Bushing
(BOM item #8)

Left Side



Figure 22: Top mount/stem parts installation complete



Right Side

E4-WM5-Y764A00 MOUNTING INSTRUCTION



AA. With the upper shock mount secured, install the lower shock mount using bolt/washer removed in step A. Thread until hand tight (bolt will be torqued at a later step). Refer to Figure 23.



Figure 23: Lower mount installation

Left Side Shown

BB. With the rear suspension drooped out, make sure the Anti-Rotation Pin is not contacting the Anti-Rotation Plate. If it is contacting, loosen the Nylock; M6x1 (BOM item #3) and slide the Anti-Rotation Pin forward slightly until there is a small gap (~1/16"). Re-torque Nylock; M6x1 according to step V.

CC. With the main shock body in place, route the reservoir and reservoir hose toward the center of the vehicle, and then in front of the main shock body. Refer to Figure 24.

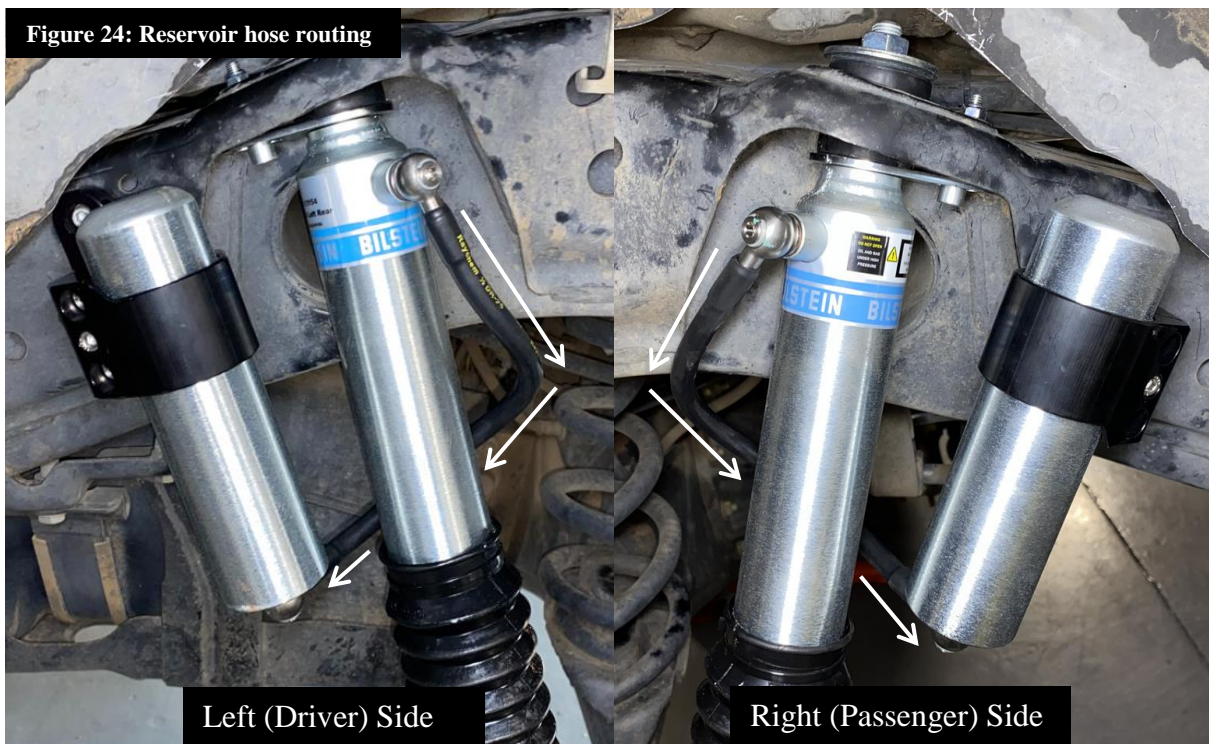

Figure 24: Reservoir hose routing

Left (Driver) Side

Right (Passenger) Side

E4-WM5-Y764A00 MOUNTING INSTRUCTION



- DD. Slide the two M8x1.25 SHCS (BOM item #13) through two Split Lock Washers (BOM item #14), then through the two holes in the Reservoir Bracket.
- EE. Apply non-permanent thread locker to the remaining exposed M8x1.25 threads.
- FF. Secure the Reservoir Bracket to the Reservoir Bracket Adapter by screwing both M8x1.25 SHCS into the Reservoir Bracket Adapter using a 6mm hex driver. Refer to Figure 25.
- **Torque: 12.5 ft-lb (17 Nm)**

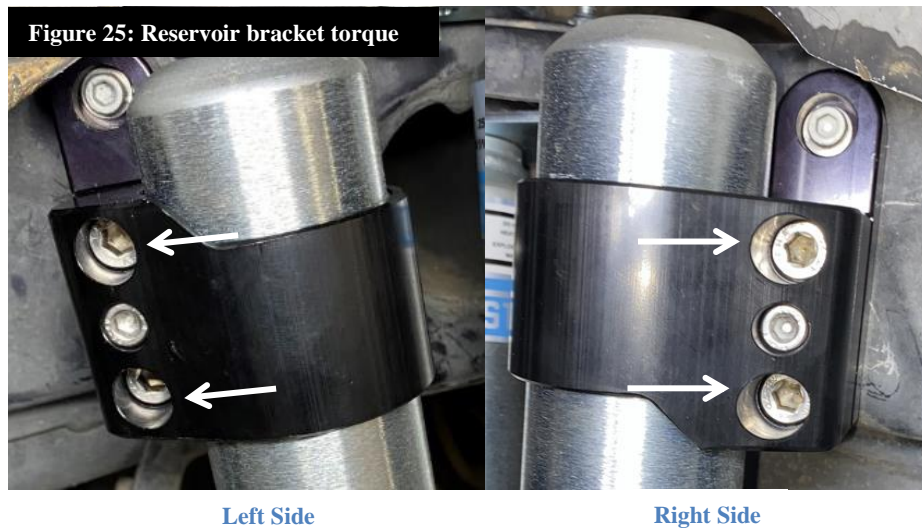

Final left rear (driver) B8 5160 reservoir shock installed on vehicle, refer to Figure 26.



Note: The shocks depicted herein may differ slightly in appearance from the supplied components.

E4-WM5-Y764A00 MOUNTING INSTRUCTION



Final right rear (passenger) B8 5160 reservoir shock installed on vehicle, refer to Figure 27.



GG. Be sure to lower the vehicle such that its full weight is on the suspension prior to fully tightening the lower mount fasteners to the vehicle manufacturer's service manual torque specification.

Anti Rotation component service:

The Anti Rotation Pin (BOM item #1) and Anti Rotation Plate (BOM item #4) are wear items and will need to be replaced periodically depending on usage. Check for wear every 20,000 miles and replace components if they show excessive signs of wear.

To purchase new Anti Rotation components, please contact:

THYSSENKRUPP BILSTEIN OF AMERICA
Toll Free: 1-800-537-1085
bilsteinus.com